



TANK CONTAINER DEPOT JAPAN 6 >>



cleaning  
your  
wörlD



IT'S THE FAMILY  
BEHIND THE BUSINESS

4 >>

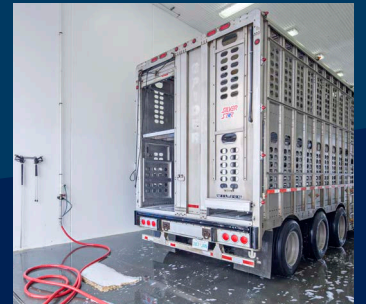

CLEANING  
LIVESTOCK CARRIERS

8 >>



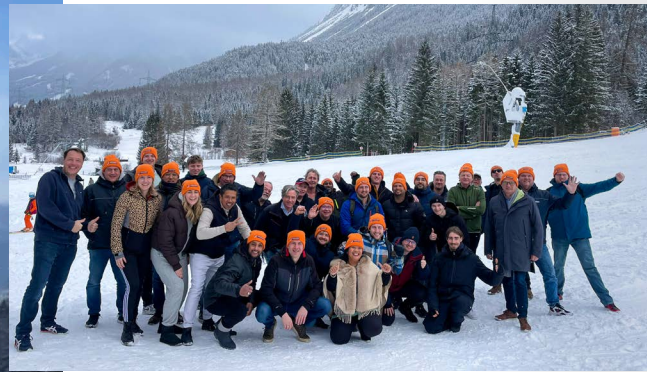

#TeamGröninger



# LOOKING AHEAD

After reflecting on 75 years of history, Gröninger is now fully focused on 'looking ahead'. The anniversary year concluded with a team event in a winter wonderland. In November, Gröninger threw a party for all employees. During 2022, various customers who are always open to reference visits with international relations were honored with a custom-built Gröninger depot bicycle (photo) as a special gift.

So now 'looking ahead'.

### Expanding local presence

Although Rotterdam is the home base, customers appreciate local presence. In addition to the existing global branch offices, the recently opened office in Worms (Germany) is taking shape. In early 2023, we started a partnership with DAWIT to serve the Polish tank cleaning market.

### Service as spearhead

Maintenance and uptime management

of cleaning systems are increasingly becoming a challenge for (inter)national customers. Lack of qualified technical personnel, the scale and complexity of the systems, digitization, automation, etc. play a role in this development. With 'Support Beyond Cleaning', Gröninger already has a service and maintenance solution that takes specific customer needs into account. In 2023, Gröninger plans to take this service concept to the next level by expanding technical staff (in-office and onsite) and investing in systems (Smartfix, customer

portal, and an improved link between operating software and reporting tools).

### New markets and products

Gröninger is continuing to shape its Tank Cleaning and Food/Non-food business and is also exploring new markets and products. A great example of this is the livestock carrier cleaning solution that Gröninger developed for Steve's Livestock in Canada. The cleaning facilities are branded as Blue Water Wash, and in close cooperation with Gröninger, a new, labor-saving, and effective way of cleaning livestock trailers was designed.

This newsletter will provide more details on the topics mentioned above and will also take you aboard to current and completed projects. We hope this will inspire you enough! 📄





GRÖNINGER - WORMS (DEU)

## MORE ABOUT GRÖNINGER GERMANY

Gröninger Germany, located in Worms, has Michael Neumann as its representative for quite some time now. Michael is a Qualified Engineer (MSc) and has many years of experience in designing and constructing technical systems and complex mechanical structures. He values the motto of 'lifetime learning' and was recently certified in Quality Management and Project Management

courses (DIN 69900 and 69901), which adds extra knowledge that benefits Gröninger and its customers. From the centrally located Worms office, Michael serves as the contact person and source of information for both new and existing customers. He recently contributed to the design of platforms, performed strength and stability calculations, and supervised various projects. 🇩🇪

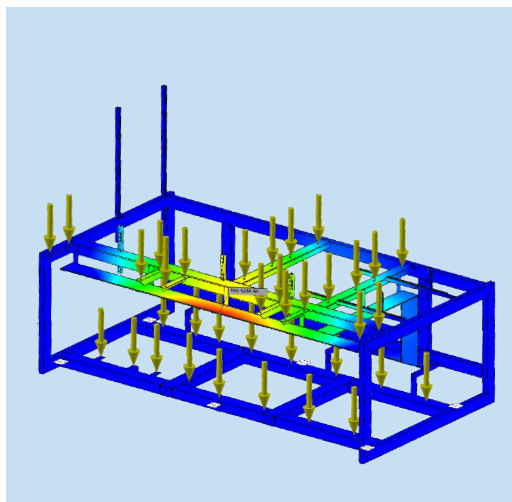

*Strength calculation for a CleanPack frame.*

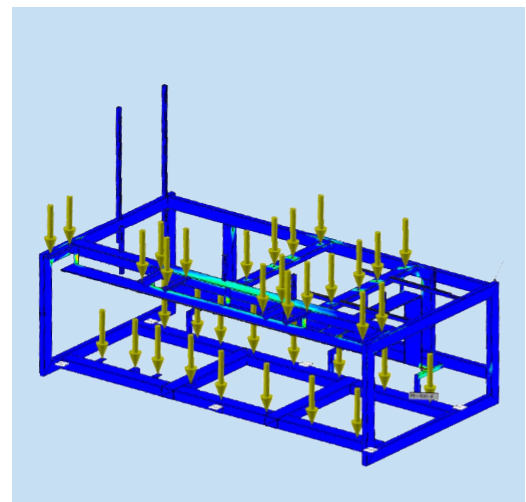

FLTR Ryan  
Chmielewski,  
Christopher Bermes,  
Heinz-Josef Bermes.



WTR - WILLICH (DEU)

## IT'S THE FAMILY BEHIND THE BUSINESS

Since 2001 an ultra-modern tank cleaning facility has been located in the Willich-Müncheide II industrial area: WTR Willicher Tankwagenreinigungs GmbH. What started with the purchase of one rotor jet to clean the WTR owned tank truck fleet, has now grown into a full-fledged tank cleaning facility, as a subsidiary of the Bermes Gruppe. WTR has been a valued Gröninger partner for many years.

**We met with Christopher, 34 years old, the fourth generation in the company.**

"With two horses and a wooden wagon, the first transport was provided by my great-grandfather. This was in 1916 and meant the birth of Gebr. Bermes Spedition GmbH," Christopher says. "In 2001 we moved from Anrath to Willich and built two chemical tank cleaning bays. Due to growing demand and increasing quality requirements of customers we decided in 2011 to further expand our range of services with the construction of an additional food only cleaning bay. For this project we chose Gröninger." Christopher adds: "Many more projects followed. From the installation of an

air purification system to replacing the complete control system and PLC software."

**Special care and individual attention**

"We like the mix of transport, cleaning and storage. A growing number of customers come to us for these combined services. At WTR they can always count on extra service and attention. The strength of WTR is that drivers who come by to clean the tanks are not considered 'a number' but are all treated as individuals. They like to come here, because they are treated seriously and friendly. They can use good and clean sanitation areas with showers and toilets, but also enjoy food and drinks. And that's worth a lot. We strive to create a welcoming and friendly



environment where drivers feel at home.”

### Access to the cleaning data

“We use the Gröninger Cleaning Guard system for monitoring and documenting the cleaning process. This way we offer the customer insight into the cleaning data. Our system helps to validate that the tanks meet the required standards. For example, before a tank can be regarded as kosher, a minimum temperature and steaming duration must be reached. This is definitely a requirement in the food industry. So that is perfectly validated.”

### Power of cooperation

“My father always said that it’s good if the customer has a problem, because only then we can solve it and help them. And that’s exactly what we do. But we also expect that from our partners. If we have a technical problem, we call Gröninger, if urgently needed even outside office hours. Gröninger is always available to us. Of course, downtime is not considered an option; in these cases Gröninger remotely takes over the system or comes to our site to bring the technical solution. Gröninger offers us the quality of service that we offer to our customers. Trust is such an important element of any successful collaboration, and it’s clear that we have built a strong foundation of trust over the years.”

### Building a sustainable future

“Before COVID-19, we cleaned about 60 tank trucks per day. That temporarily decreased a bit. We now see an upward trend again,” Christopher conti-

nues: “The last few years were challenging, not just because of the corona crisis but also due to the war and its consequences. Consider just alone the price increases that happened. That kept us very busy. Our internal costs increased as well. In cooperation with Gröninger we are executing a plan to make our cleanings more sustainable. With the data from the system we make reports that show what we emit and where we can achieve savings, both financially and environmentally. With the new measures and actions we ensure that CO2 emissions are reduced in combination with more financial benefits to the bottom line.”

Christopher elaborates: “With the entire Bermes Gruppe we have long-term perspective when it comes to investments and sustainability. My parents have been active in the tank cleaning market for 20 years. During this period they also experienced many other crises. There are always ups and downs, but that keeps us sharp and competitive. Together with Gröninger we continue to build our future.” 🏡

*Gröninger Senior Service Engineer Rivany Paimo has been a familiar and reliable source of support at WTR for many years.*







MEIKO - NAGOYA (JPN)

## TANK CONTAINER DEPOT

The city of Nagoya, Japan, is home to Japan's largest seaport. For this reason alone, it is not surprising that Meiko Trans has chosen Nagoya as a location for the construction of a very modern tank container depot.

At the new depot, any type of tank container is

cleaned using a high-pressure system and a low-pressure chemical circulation unit. The layout of the system was designed in close consultation and based on a visit by the Meiko delegation to Rotterdam. Upon arrival in Japan, the system was connected with piping and cabling and commissioned by a Gröninger Project Engineer. 🇯🇵

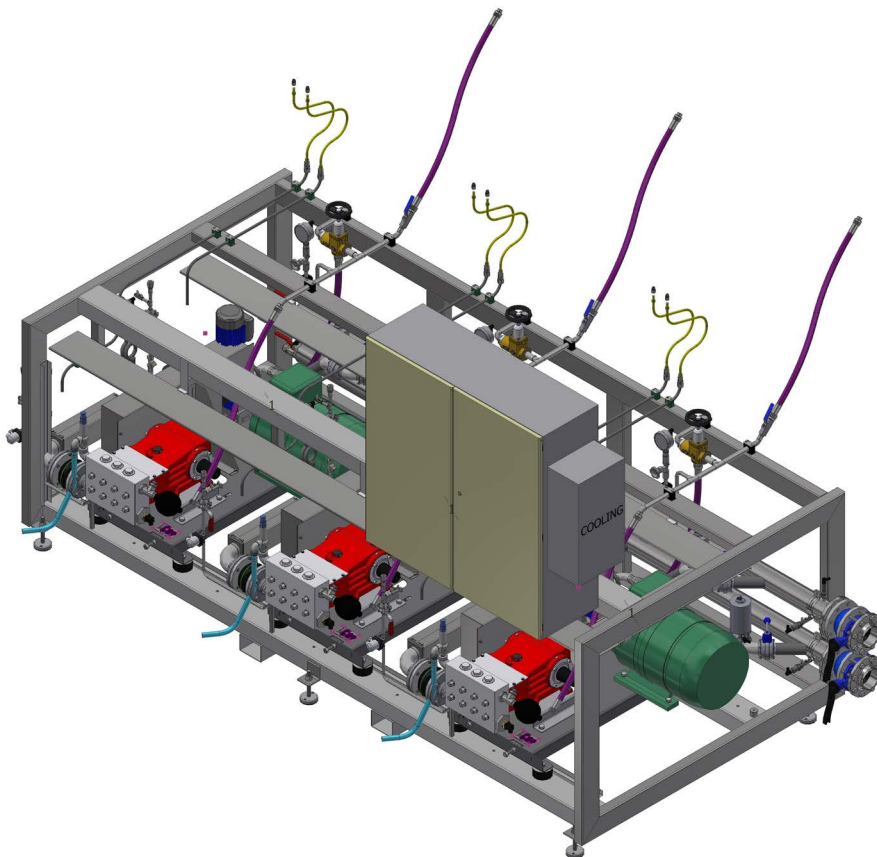

TCI CHEMICALS  
LOGISTICS SOLUTIONS  
(IND)

## CLEANING IN INDIA

Transport Corporation of India Ltd. (TCI) is India's leading logistics and integrated inter-modal service provider. The Indian market is evolving rapidly, and the country is getting ready for the future with numerous modernization projects.

This is the case as well at TCI. The company recently started setting up a network of ISO tank container depots. Together with Gröninger a large tank cleaning facility will be built in order to provide a full range of services to a wide range of customers. The first three bay tank cleaning will be operational in the summer 2023. 🇮🇳



GEODIS - LEKKERKERK (NLD)

## SECOND CLEANING BAY

Geodis recently built a second cleaning bay at the Lekkerkerk location. This means that chemicals and food can be perfectly and separately cleaned on dedicated bays. Geodis in Lekkerkerk specializes in cleaning beer tanks. The second bay is fed in alternating mode by the original tank cleaning system, that was built by Gröninger back in 2012. 🏗️

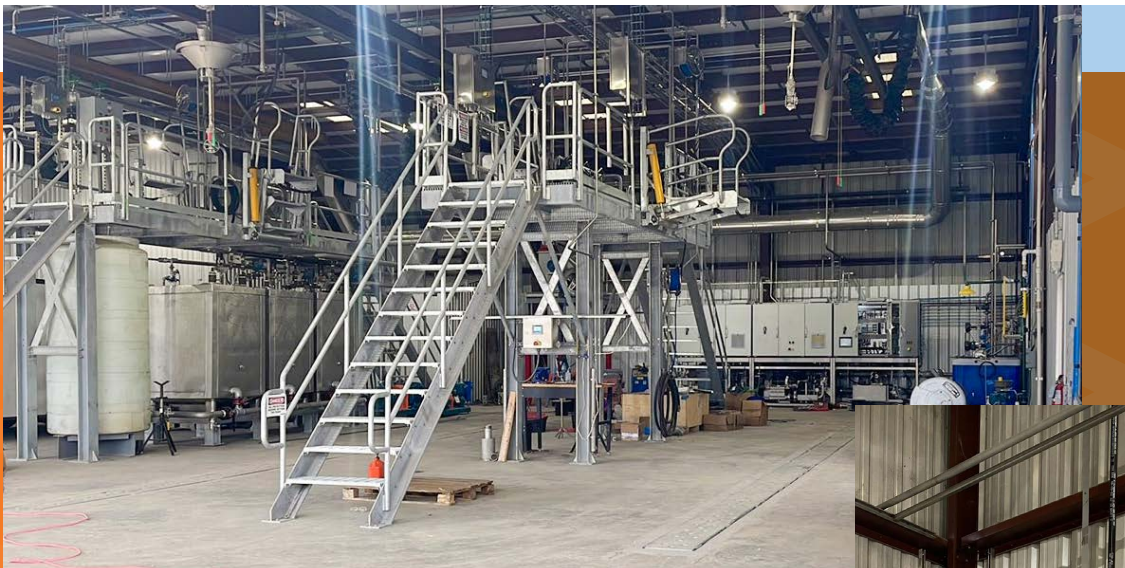

QUALA - LA PORTE (USA)

## HIGH SPEED, HIGH PRESSURE

Quala is by far the largest tank cleaning service provider in North America. Since 2019, Quala and Gröninger have been working together to introduce Gröninger's high pressure, low water volume technology in the United States. With this technique, considerable time savings for Quala's customers can be achieved in combination with much better quality.

The former Polar site in La Porte (Texas) was recently equipped with a Gröninger system. Together with Quala Gröninger is working on a plan to further roll out the technology through the expanding Quala network. 🏗️







BLUE WATER WASH - BLUMENORT (CAN)

# CLEANING LIVESTOCK CARRIERS

**Sometimes something terrific just seems to happen... In recent years Gröninger built several tank cleaning facilities in North America. The guiding principles in all these systems are efficiency, high pressure and low water volume all combined in the pursuit of the highest possible quality level. This has not gone unnoticed in the market.**

In the fall of 2021, Steve Brandt, owner of Steve's Livestock, visited a Gröninger system in Canada. He immediately saw the potential for his own business. Steve's Livestock is one of the largest livestock carriers in North America and operates over 140 trucks. Steve's also runs a number of livestock truck cleaning stations under the brand name Blue Water Wash.

## **Total solution**

Until recently, cattle trailers were cleaned almost exclusively in a manual way. The cleaning process was labor-intensive, time-consuming, and not very pleasant for the operators. When Steve Brandt saw the Gröninger tank cleaning system, he recognized its potential and contacted Garth Belue of Gröninger USA in Houston to develop a plan. Tests

were conducted in Blumenort using a pilot system, and the results were used to engineer an overall technical solution by the Gröninger office in Germany. This led to the development of a new system that was recently delivered and commissioned, providing a much-needed total solution for livestock trailer cleaning companies like Blue Water Wash.

## **'CleanTowers'**

An eye-catching feature of the system is the cleaning bay layout. Eight CleanTowers are erected per bay, each with two rotor jets. Through easy operations, these rotor jets are positioned in the livestock carrier. In the next step, the carrier is cleaned by a sequence of waves generated through advanced PLC control. This way, the carrier is rinsed from front to back in a short time.





### Technology in containers

The supporting technology is placed in an insulated 40ft container. This container houses two 15,000 liters/hour 100 bar pump sets, two high-pressure spray gun units, and the chemical dosing system. A large central heating boiler is placed in a separate 20ft container and takes care of heating the water. This project showcases Gröninger's strength as a global player. The basic idea and its application come from North America, the engineering from Germany, the production from the Netherlands, Italy, China, Mexico and the USA while the assembly takes place on site in Canada.

### Faith, family and hard work

In addition to the technical and creative bond, there is also a strong cultural bond between Steve's and Gröninger. As a Gröninger group we follow Steve's basic working principle and convert that easily into plural: "Our companies have been built on Faith, family, and hard work. These, together with our Core Values, keep us focused on making our companies, our industry, our customers and our communities better." 🇩🇪

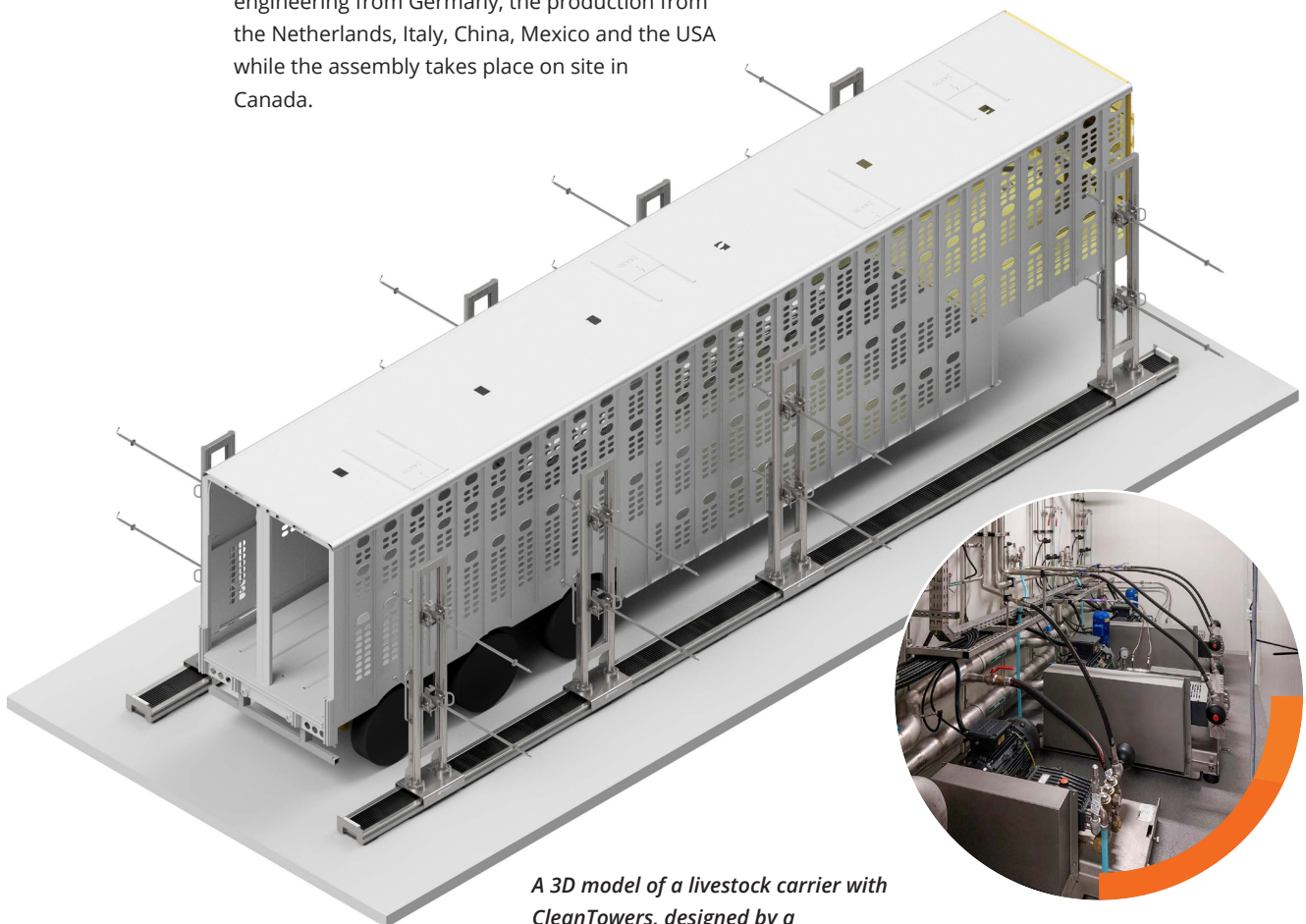

*A 3D model of a livestock carrier with CleanTowers, designed by a Gröninger Project Engineer CAD.*



KONTENA NASIONAL BERHAD - JOHOR (MYS)

## FOUR CLEANING BAYS

Kontena Nasional, a Malaysian company that started about 50 years ago when containerization trend shaped the transportation industry, recently decided to open an ISO tank container depot to perform cleanings for itself. Gröninger supplied a compact cleaning system with a steam generator and two rotor jets that can be used on four bays, allowing for the steaming and cleaning of ISO tanks.

In addition to the cleaning system, Kontena also purchased a latex circulation unit and a dryer. Both systems have electric heating, making them completely sustainable with this source of energy. 

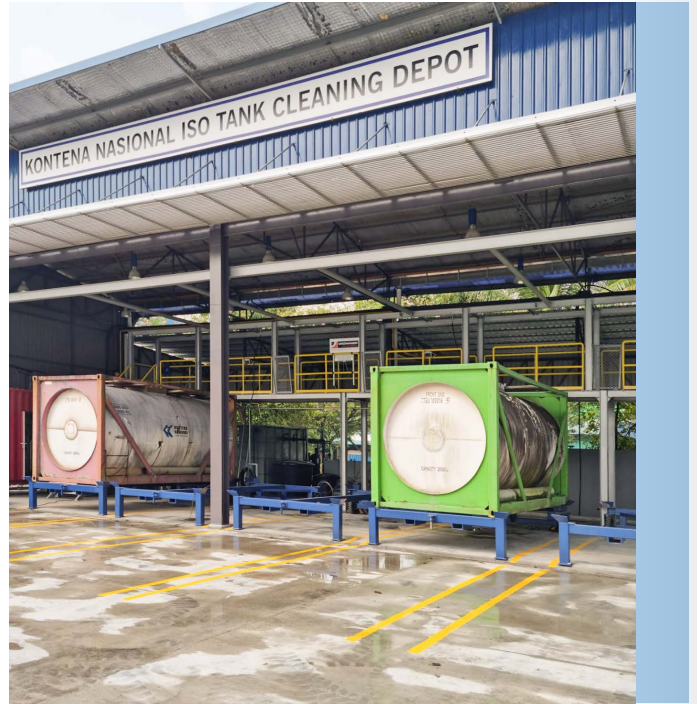

DEN HARTOGH LSC GOTHENBURG - GOTHENBURG (SWE)

## CLEANING HEAVILY CONTAMINATED LATEX TANKS

The existing tank cleaning facility at Hedenskogs Tankeri AB in Gothenburg, Sweden has been recently equipped with a latex cleaning unit. Den Hartogh, who acquired the Swedish company at the beginning of 2022, performs cleaning and heating activities at the site in addition to transport.

Cleaning hardened latex remnants is difficult with a standard high pressure cleaning system. Gröninger developed a fully automatic latex circulation unit dedicated to this purpose, which is continuously modernized. By using a heated batch with a chemical cleaning agent, the latex is dissolved in the tank, eliminating the need for manual work. Together with the customer, Gröninger analyzed how the operations could be carried out as energy efficiently as possible, and selected an electric-powered return pump to reduce compressed air consumption.

The unit is placed in a 20ft technical container with a work platform on top, allowing tanks to be cleaned on a separate bay without disturbing regular tank cleaning activities. 





Contact us at [info@groninger.nl](mailto:info@groninger.nl) or check our website and find the colleague near to you.

# DRYING: A CRUCIAL STEP IN THE CLEANING PROCESS

It will come as no surprise that a tank is wet after cleaning with water and/or steam. Often that's not a problem. In fact, sometimes it is even desirable that a tank remains moist. However, there are also products that do not tolerate water well, so the tank must be dried after cleaning.

## Electric air heating

Gröninger's Drypack, which has been available for years, is a modular system that consists of filters, a heating element, and a fan. The system traditionally used steam or hot water to heat the air, but an alternative was developed last year that

heats the air using electrical power.

The hot air is blown into the tanks through stainless steel pipes, ensuring that they leave the cleaning bay completely dry and ready for the next loading location in just a few minutes after cleaning. 🇳🇱



Wemmers, H&S and ITC recently all opted for a new efficient dryer. Are you curious about the possibilities at your site? Contact us at [info@groninger.nl](mailto:info@groninger.nl) or check our website and find the colleague near to you.





COTAC - MANNHEIM (DEU)

# FULLY AUTOMATIC CONTAINER CLEANING

Cotac has been cleaning IBCs and stainless steel containers at the Mannheim site for many years. Many of the products transported in these containers find their way into the pharmaceutical industry. To safeguard the quality of the cleaning and to make cleaning less labor intensive, Gröninger has designed, built, and commissioned a fully automatic container cleaning system for Cotac.

### Purify released vapors

The system is equipped to process various container formats. A forklift truck places the container on the stainless steel chain conveyor. Next, the container is moved automatically through different sections. The section where residual product is removed is connected to an air purification system, where the released vapors are purified.

### Drying or sterilization

Both the exterior and interior cleaning are carried out in a closed, fully automated booth. The associated high-pressure technology is built in a

20ft container. Stickers are removed very quickly using a 500 bar spray gun. Afterwards, the containers are dried with hot air and/or sterilized using steam.

### Reporting tool

Cleaning and process data are processed by a PLC, exported as files, and digitally sent to the customer's systems. This means that the cleaning history of a container can always be referred to when asked for. 📄





EMSLAND FRISCHGEFLÜGEL - HAREN (DEU)

# LIQUID RESIDUAL PRODUCT

Emsland Frischgeflügel processes chickens into various end products. This process generates liquid waste that is further processed into animal feed. Frischgeflügel recently acquired its own tank trailers for the transport of this liquid residual product.

## Insourcing of logistics and cleaning

With the use of owned trailers, the need for in-house cleaning emerged. The cleaning system was supplied as a plug-and-play unit and could be easily placed in the existing washing area and

pipes, and cables could be kept rather short. The setup allows tanks to be cleaned on two bays. After cleaning, the process parameters are extracted from the PLC, and a cleaning certificate is created in the online Gröninger Cleaning Guard software environment.

## Expansion

With the successful construction of the cleaning facility in Emsland, a sister company, Celler Land Frischgeflügel, also decided to purchase its own cleaning facility. 🇩🇪







GIVE KONFEKTURE - GIVE (DNK)

## CLEANING IN THE FOOD INDUSTRY

With the construction of a professional Gröninger cleaning system, Give Konfektur can refill its food containers with full peace of mind.

Give uses stainless steel tanks to process marinades, dressings and fruit mixtures. By using the combination of hot water, cleaning agents, steam and disinfectant, tanks are cleaned in accordance with the strict hygiene regulations in the food industry. 🇩🇰



RENEWI (NLD)

## WASTE NO MORE

Under the slogan "Waste no more", Renewi focuses on extracting value from waste rather than incinerating or dumping that waste. To achieve this goal, very good equipment is a must. That's why Gröninger has been a Renewi partner for decades. Some systems built for Renewi have been in operation for over 25 years. Here sustainability speaks for itself.

In 2023, Gröninger supplied a wheelie bin cleaning machine to a Renewi site. This piece of equipment is suitable for both steel and plastic wheelie bins. Cleaning takes place with rotor jets

fed by high-pressure pumps. Water comes from an integrated (hot) water system.

For another site, Gröninger has developed a system to be integrated in the processing facility for expired products from a large supermarket chain. Key element is a screw conveyor (supplied by a third party); Gröninger has installed the equipment (pump unit, sprinklers, wastewater drainage system, etc.) to keep this screw conveyor thoroughly clean. Collaboration at its best. 🇳🇱



# SUSTAINABILITY IN 2023



In the past year, the world has faced an energy crisis, and its effects are being felt in the tank cleaning market. Rising prices of resources like natural gas and electricity have led to a search for sustainable energy alternatives.

The Paris Climate Agreement's goal of reducing carbon footprint and emissions has given an extra boost to this search. The good news is that sustainability efforts now directly lead to cost savings and have healthy paybacks.

Gröninger has recently implemented various sustainable solutions for a large number of customers. Some eye-catching systems are highlighted below:



Fully solar-powered tank cleaning at Boonzaaijer (NLD) uses **electric powered heating** for rinsing water and hot air for the dryer.

For Kontena Nasional (MYS), Gröninger developed a new electrically heated latex circulation unit. This customer also operates an electric Gröninger dryer.



**Reusing wastewater** at Stolt Moerdijk (NLD) leads to approximately 70% water savings, but also a considerable reduction in natural gas consumption since residual heat is recovered from the wastewater.



The conversion of systems with cold water-fed pumps to hot water-fed pumps was recently carried out at Stubbe (NLD). The result is much higher **energy efficiency**.

Replacing switch valves for pumps with modern electronically controlled valves to achieve a pre-set temperature leads to considerable energy efficiency gains.



Integrating **heat recovery systems**, such as flue gas condensers and wastewater heat exchangers, leads to considerable energy savings for many customers.



Finally, all kinds of **sustainable energy sources**, such as heat pipes, solar systems, heat pumps, etc., deserve our and your full attention. 🚀



**At Gröninger, sustainability is not just theory but practice.**

*This is evident from numerous cases that have been carried out. Gröninger considers it a prime task to search – together with the customer – for the best economically and environmentally friendly solutions in a specific customer situation. Without any doubt, a 'free of cost' sustainability scan leads to highly profitable investment suggestions. Take on the challenge and get in touch with Gröninger!*



Are you curious about the possibilities at your site? Contact us at [info@groninger.nl](mailto:info@groninger.nl) or check our website and find the colleague near to you.





**Gröninger Cleaning Systems B.V.**

**Head Office**  
Overschiepweg 111  
3044 EH Rotterdam  
The Netherlands  
+31 10 437 10 22  
info@groninger.nl

**Subsidiaries**  
Worms (DEU)  
Houston (USA)  
Singapore (SGP)  
**Representative Offices**  
Mumbai (IND)  
Shanghai (CHN)  
Gdynia (POL)

groninger.eu  
webshop.groninger.nl  
portal.groninger.nl



**cleaning  
your  
wörl**

